

SECTION A-A

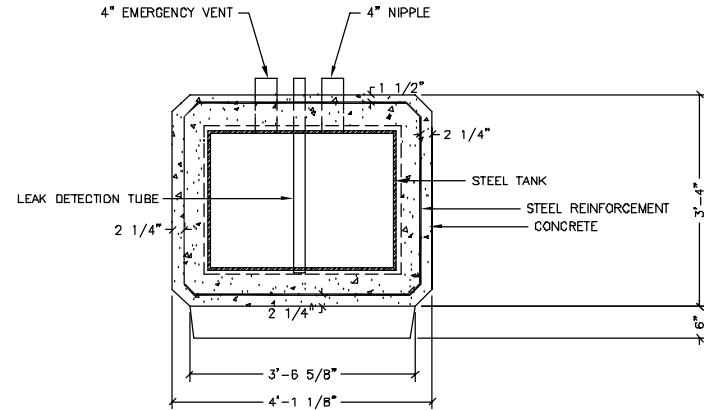

SECTION B-B

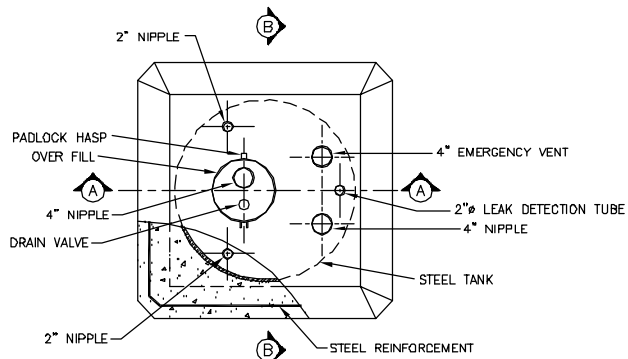

PLAN VIEW

CORNER DETAILS

N.T.S.

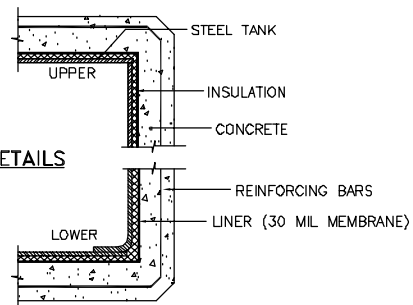

- 20 YEAR WARRANTY 30 YEAR WARRANTY
- 7 GALLON U.L. LISTED OVERFILL CONTAINMENT (OPTIONAL)

STANDARD TOP DESIGN SHOWN, OTHER DESIGNS AVAILABLE.
TANK MUST BE SET ACCORDING TO CONVAULT INSTRUCTIONS IN ORDER TO ACTIVATE WARRANTY.

PLANT LOCATION:		WEIGHT:	
WILDWOOD, FL		REVISION DATE	06-03-04
TANK SIZE	125 GALLON	DRAWING NUMBER	88153004

Core Engineered Solutions, Inc.
620 Herndon Pkwy, Suite 120
Herndon, VA 20170
(703) 563-0320 (703) 563-0330 FAX
www.core-es.com info@core-es.com

